

Specifications and Installation

ExoKids Tai Chi Spinners (CTCS)

ExoKids

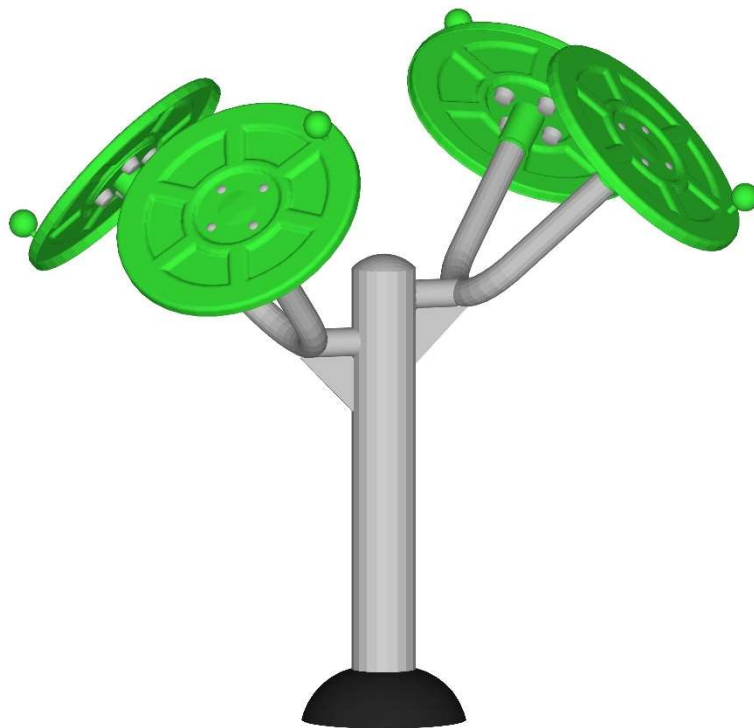

ExoFit Outdoor Fitness Equipment

*****AFTER EQUIPMENT IS INSTALLED, REMOVE ALL FILM OFF LABELS*****

DIMENSIONS:

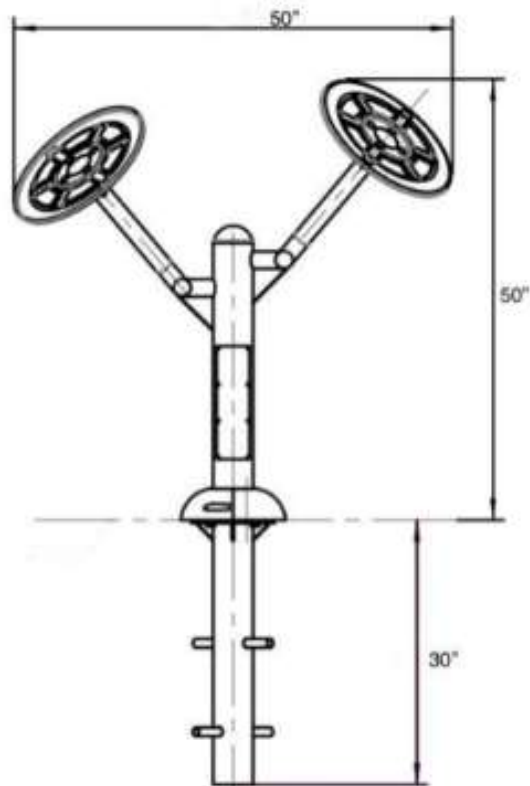
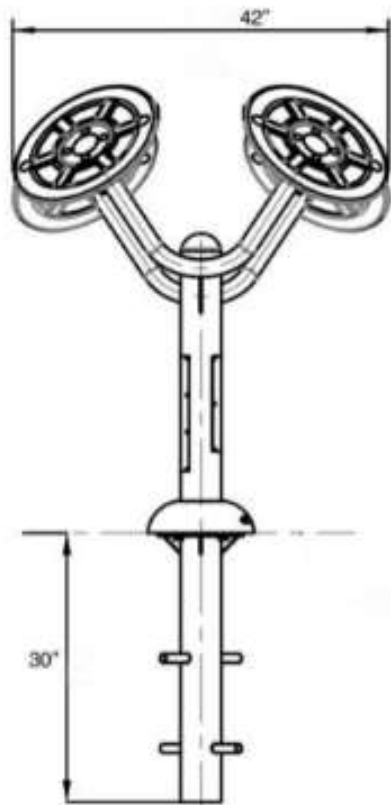

USE ZONE:

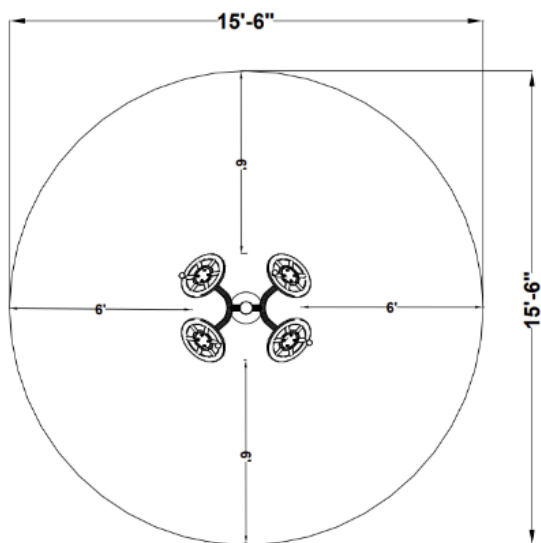

*****AFTER EQUIPMENT IS INSTALLED, REMOVE ALL FILM OFF LABELS*****

SURFACE MOUNT INSTALLATION:

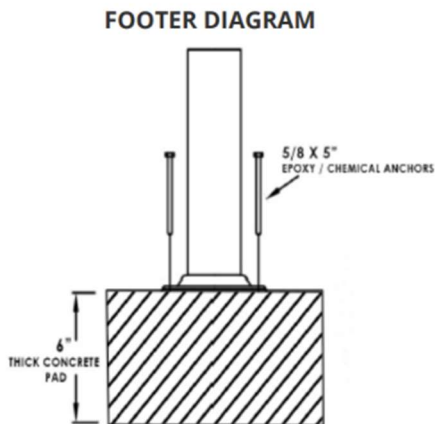

For best results, a 6" thick concrete pad is recommended.

5/8" x 5" Epoxy/Chemical Anchors are recommended for Surface Mount.
(epoxy anchors not included)

Base Covers:

Please note that the M8*30 bolts for the base covers are included inside the base cover plate.

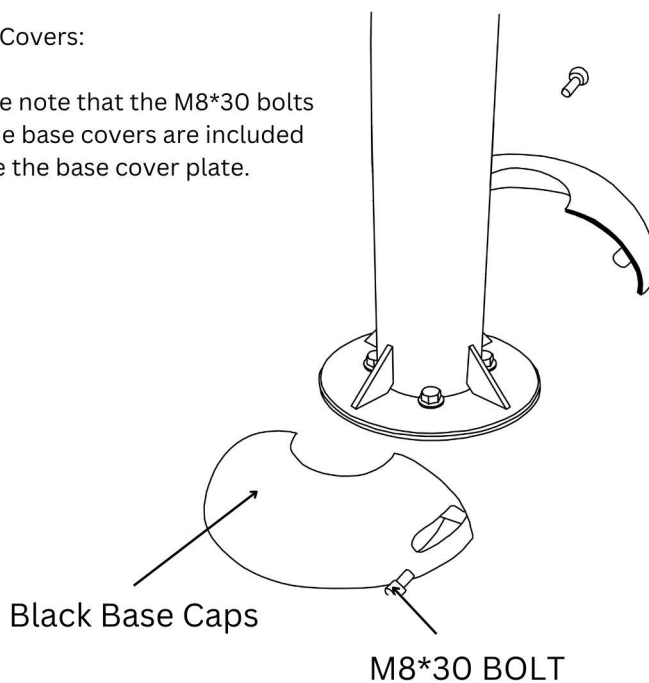

***** AFTER EQUIPMENT IS INSTALLED, REMOVE ALL FILM OFF LABELS *****

IN-GROUND MOUNT INSTALLATION:

Attach embedded anchors to the bottom of all posts first before putting them into footers. All bolts needed for in-ground installation of the embedded anchors are attached to the anchors.

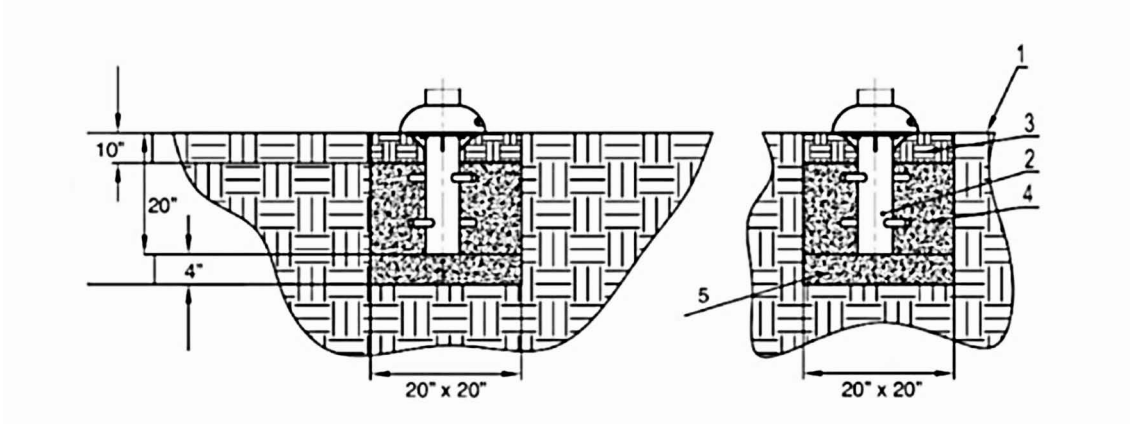

Ref	Name
1	Ground Level
2	Anchor
3	Topsoil
4	Concrete
5	Concrete Block

FOR SOFTER SOIL CONDITIONS, WE RECOMMEND 30" L x 30" W x 24" H.